

RFID Based Digital Passport Reader/ Scanner System

About This Project:

The project designed is an authentication system where the passport holder is authorized through RFID technology. The passport holder would have an RFID tag which contains all the passport details like name, number, nationality etc. This tag has to be swiped over the reader and the information thus read is provided to a microcontroller Arduino family. This information is matched with the one stored in the microcontroller, if the data matches microcontroller displays a confirmation message otherwise displays a denial message on a LCD screen. The status of a particular person can also be obtained through a status button in the system. To design a prototype that will resemble the operation of an e-passport booklet but using an RFID card eliminating the conventional paper passport booklet. The objective is to improve passport security by creating a stronger link between the passport and its holder.

Block Diagram:

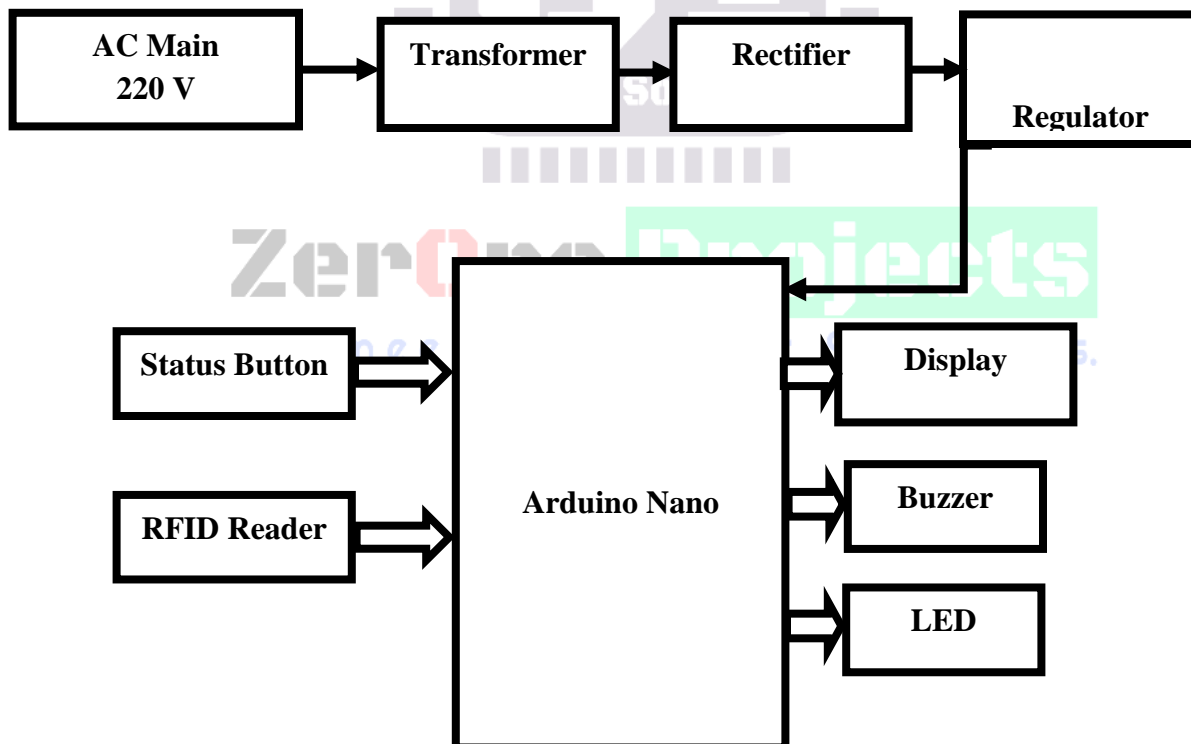

Figure: Block Diagram of Digital Passport Reader/ Scanner System

Required Instruments:

1. Arduino Nano
2. RFID Module & Cards
3. LCD Display
4. Resistors
5. Capacitors
6. Transistors
7. Cables & Connectors
8. Diodes
9. PCB
10. LED's
11. Transformer
12. Push Button
13. Buzzer



ZerOne Projects
Engineering Project Solutions.

N.B: For This Project Details & Customized Development or to Get Any Engineering Project Solutions Contact with Us.

Office:

Road#04, Plot#03, Sec#6/Ka,
Mirpur-2, Dhaka-1216

Web & Mail:

www.projects.zeronebd.com
projects.zeronebd@gmail.com

Contact:

01676 99 80 99
01714 80 84 02