

Bidirectional Visitor Counter Based Load Control System.

About This Project:

The project of “Bidirectional Visitor Counter Based Load Control System” is based on the interfacing of some components such as IR sensors, Relay etc. with Arduino microcontroller. This counter can count people in both directions. This circuit can be used to count the number of persons entering a hall/mall/home/office in the entrance gate and it can count the number of persons leaving the hall/mall/home/office by decrementing the count at same gate or exit gate and it depends upon sensor placement in hall/mall/home/office. It can also be used at gates of parking areas and other public places. This project is divided in four parts: sensors, controller, counter display and gate. The sensor would observe an interruption and provide an input to the controller which would run the counter increment or decrement depending on entering or exiting of the person. And counting is displayed on a 16x2 LCD through the controller. In this project we have used two IR sensor modules which sense the object or person. Arduino Nano is used for controlling whole the process of this visitor counter project. The relay & IR Sensor are connected with Arduino. Arduino read IR signals and send commands to relay driver circuit to drive the relay for light bulb controlling. Display section contains a 16x2 LCD. This section will display the counted number of people and light status when no one will in the room. Relay driver section consist a BC547 transistor and a 5 volt relay for controlling the light bulb. Transistor is used to drive the relay because Arduino does not supply enough voltage and current to drive relay. So we added a relay driver circuit to get enough voltage and current for relay. Arduino sends commands to this relay driver transistor and then light bulb will turn on/off accordingly.

Office:

Road#04, Plot#03, Sec#6/Ka,
Mirpur-2, Dhaka-1216

Web & Mail:

www.projects.zeronebd.com
projects.zeronebd@gmail.com

Contact:

01676 99 80 99
01714 80 84 02

Block Diagram:

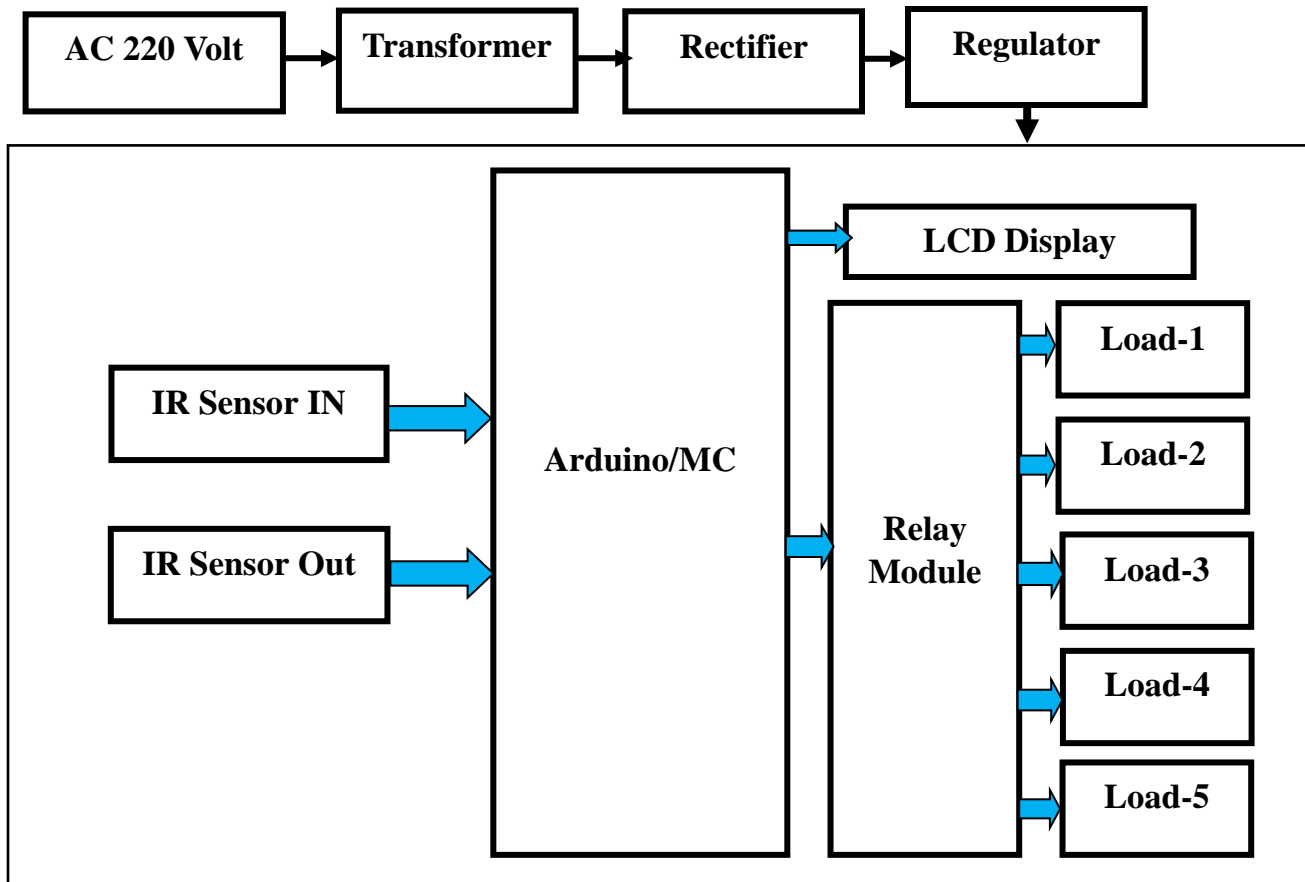

Figure: Block Diagram of Bidirectional Visitor Counter Based Load Control System.

Required Instrument:

- Arduino Nano.
- LCD Display.
- Relay.
- IR Sensor.
- Transistor.
- Transformer.
- Diode.
- Capacitor.
- Voltage Regulator.

Office:

Road#04, Plot#03, Sec#6/Ka,
Mirpur-2, Dhaka-1216

Web & Mail:

www.projects.zeronebd.com
projects.zeronebd@gmail.com

Contact:

01676 99 80 99
01714 80 84 02

Advantages:

- Energy loss will be prevented.
- Cost Effective.
- Saves time and physical work.
- This project is easy to use.
- If this system is used everywhere the country's electricity demand will be met well.
- It will be known how many people entered and left the office/House/Mall/Hall.

Applications:

The project has a major application in the

- Homes can be used.
- This System can be used Restaurants, conference rooms, shopping malls, etc.
- Hospital & Clinic. And
- In many places this project can be widely used.



N.B: *Any modification of this project can be done as per your requirement. We will make the project according to your needs. Contact us with your any innovative engineering projects idea. We will help you to implement your project.*

Office:

Road#04, Plot#03, Sec#6/Ka,
Mirpur-2, Dhaka-1216

Web & Mail:

www.projects.zeronebd.com
projects.zeronebd@gmail.com

Contact:

01676 99 80 99
01714 80 84 02